



ENGINEERED TO ENTERTAIN

CYRUS CD t CD PLAYER

SERVICE MANUAL



SPECIFICATIONS

Digital output	Coaxial and Optical SPDIF
Output voltage	500mV pk-pk
Output impedance	75Ω
Optical output	Toslink
Sample rate accuracy	44.1k ± 50ppm
Clock jitter	<80ps
Disc compatibility	CD Audio, CD-R
Dimensions (H x W x D)	73 x 215 x 360 (mm), 2.8 x 8.4 x 14.1 (inches)
Weight	3.3kg

SERVICE CAUTIONS

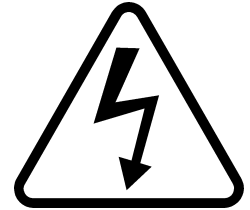

These two symbols shown are displayed prominently on the CD player base cover label. They indicate that the following cautions must be observed by all personnel-

CAUTION: TO REDUCE THE RISK OF ELECTRICAL SHOCK, DO NOT REMOVE COVER OR BACK.

THERE ARE NO USER SERVICEABLE PARTS INSIDE THE PRODUCT.

ALWAYS REFER SERVICING TO QUALIFIED SERVICE PERSONNEL.

CAUTION! LIVE MAINS VOLTAGES ON THE MAIN PCB!

When undertaking any repair work on the CD player, engineers should note that the player includes a switching power supply connected directly to live mains and other high voltages, located on the main PCB in the area highlighted in the red box.

To avoid the danger of electric shock -

- Always unplug mains power before removing the main PCB.
- Never connect mains power to the mains inlet or main PCB if the main PCB has been removed from the chassis.
- When tracing signals anywhere on the main PCB exercise caution to keep fingers, tools and test probes etc away from the high voltage power supply section of the PCB.
- Never use a grounded test probe to test the high voltage (primary) part of the power supply.
- Ensure that the chassis insulator is correctly fitted under the mains PCB before refitting it into the chassis.

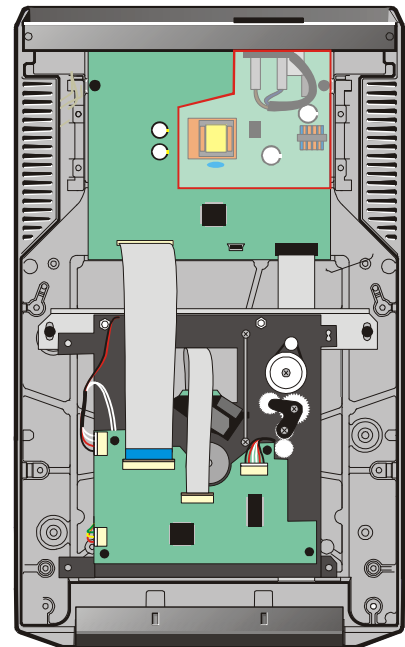

SERVICE CAUTIONS

The photo below shows the position of caution labels that alert the service technician to the presence of a laser device –

On the back panel

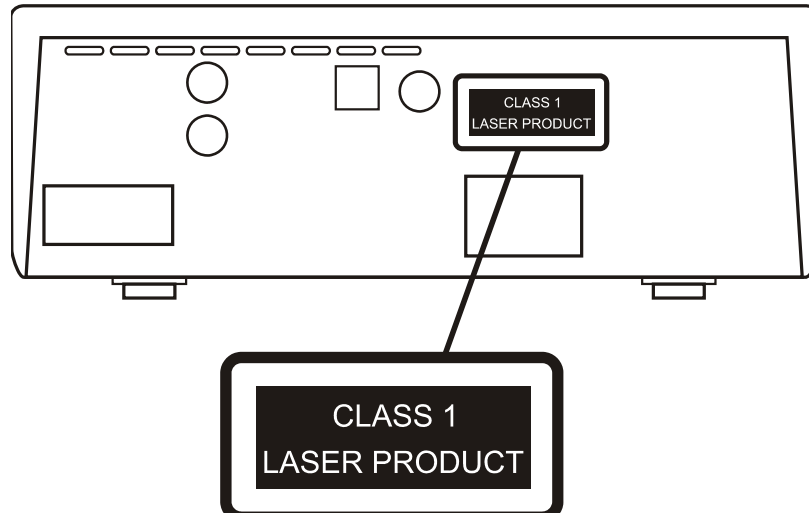

And on the disc loading mechanism



INDEX

SMD component replacement..... 2
Type identification 4
Block diagram 5
Technical description 6
Fault finding/disassembly 8
Flash Software 11
MC-BUS operation 12
Chassis parts drawing/list 13
Front panel parts drawing/list 15
Main PCB parts list 16
Servo PCB parts list 21
Circuit diagrams 24

SMD COMPONENT REPLACEMENT

Handling

SMD resistors and capacitors are widely used in the Cyrus range of products. When handling SMD components, certain precautions should be observed-

Handling SMD resistors and capacitors

- Always store SMD components in their original packaging or in a cool dry environment.
- Always handle SMD resistors and capacitors with tweezers or a vacuum pencil.
- Never handle SMD resistors and capacitors with fingers.
- Hold the SMD component by the body, not by the ends.
- Do not use SMD resistors or capacitors if the ends are dirty or discoloured.
- Do not use SMD resistors or capacitors if they have been dropped on the floor- they may be internally damaged.
- Always use replacement components of the correct size and shape. SMD components are available in many different packages. Where possible, order original parts from Cyrus.

Handling SMD ICs

- Always store these components in their original packaging or in a cool dry environment.
- Always handle SMD transistors and ICs with tweezers or a vacuum pencil.
- Never handle SMD transistors and ICs with fingers.
- Ensure that the connection pins of larger multi-pin ICs are not deformed or damaged before fitting.

Measuring circuits with SMD capacitors and resistors

- Avoid using sharp, pointed probes directly on the component end caps.
- Measure voltages from the PCB pad next to the component.

Static precautions

SMD components, particularly ICs, may be damaged by the static levels present in the workshop. Damage caused by static may not immediately cause component failure but could cause partial damage and a possible failure in the future. Observing these simple SMD precautions will avoid product failures related to static damage-

- Always wear a grounded wristband when replacing *any* electronic components.
- Always store components in their original packaging or conductive plastic bags.
- Never store components in plastic trays or bags without protection.

Soldering/desoldering SMD components

- Never re-use old SMD components after de-soldering!
- Always apply solder heat directly to the contact area. Avoid over-heating adjacent components.
- Always repair SMD PCBs with the correct tools. SMD components can only be replaced with a hot air pencil or soldering iron designed for SMD components, preferably with temperature control.
- Keep the soldering temperature as low as possible. 370°C is recommended for Lead free SMD rework. Most SMD components will withstand 370°C for 5 to 10 seconds

SMD COMPONENT REPLACEMENT

- When using solder paste a pressure dispenser should be used to ensure the correct amount of solder is applied to each pad.
- Solder paste should not be used with direct heating methods as the solder between component pins may not be melted.
- If necessary, remove excess solder paste with solder braid.

Removing SMD resistors and capacitors from the PCB with a soldering iron

1. Fit the soldering iron with a tip large enough to bridge both ends of the component.
2. Place the soldering iron so that its flat tip will heat both ends of the component at once.
3. When the solder melts, remove the component with tweezers.
4. Allow the PCB to cool for a few minutes, removing any excess solder with desoldering braid.

Fitting replacement SMD resistors and capacitors to the PCB with a soldering iron

1. Apply a little flux to the connections.
2. Place the component in position.
3. Tin the soldering iron, bring the tip into contact with the PCB pad and flow solder to the joint. Avoid bringing the soldering iron tip directly into contact with the component.

Removing SMD ICs from the PCB

1. Using fine tipped side cutters or tweezer cutters, snip all the leads of the device and remove the IC body.
2. Desolder the leads from the PCB pads.
3. Clean up the PCB with solder braid.

Removing SMD ICs with a hot air SMD tool

1. Fit a suitable size tip for the IC being removed.
2. Heat the IC evenly until the solder melts.
3. Remove the IC with tweezers.

Fitting replacement ICs to the PCB with a soldering iron

1. Check that the pins of the IC are not distorted.
2. Using tweezers, position the IC over the footprint.
3. Check that all the IC pins are correctly aligned with the pads.
4. With a very fine tip soldering iron, solder in the pins at the corners of the IC.
5. Re-check the alignment and correct if necessary.
6. When the alignment is OK, solder the remaining pins of the IC to the PCB.

TYPE IDENTIFICATION

Rating label

The CD t carries a rating label on the rear panel, which includes details of the rated power supply voltage.

Nominal power voltage

This will be either 220-230V For use on nominal 220V - 240V AC mains supply.

Power consumption

The maximum power consumption figure is indicated.

Serial number

Each CD player carries a serial number code, which identifies the following-

- Type of product
- Market destination
- Build number
- Paint finish (colour)

The serial number is on the baseplate. It is therefore important to ensure that a baseplate removed from a product is re-fitted to the same product. In any communications with Cyrus Service or Quality departments it is essential that the full serial number is quoted so that original specification parts and service information may be supplied.

PCB Identification

Each PCB is marked with a design revision number and this number should be quoted in all correspondence to the service department when requesting technical advice or requesting spare parts. The table below shows a typical PCB marking.

Revision number	PCB marking
Main board revision 1	IS2112N1

BLOCK DIAGRAM

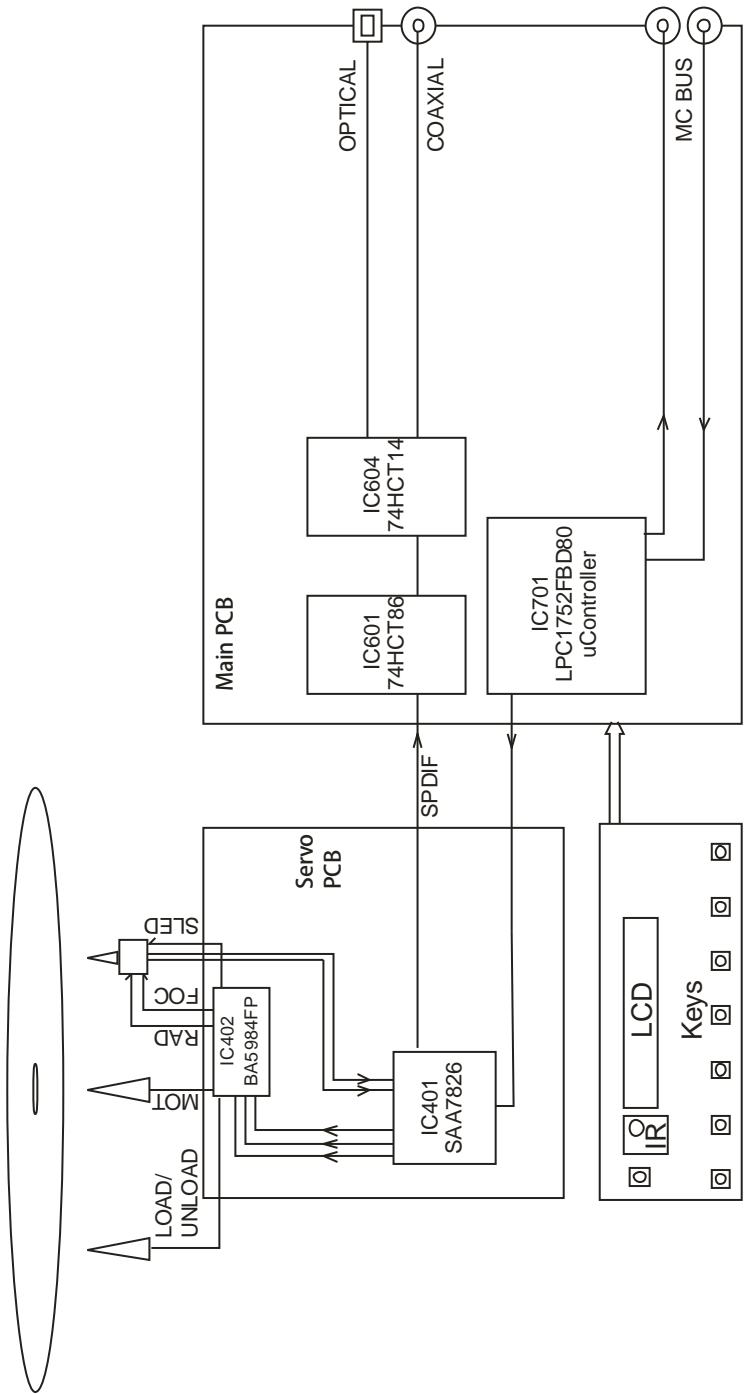

TECHNICAL DESCRIPTION

PCB assemblies

The following is a brief description of the internal PCBs found in the CD t.

The **servo** PCB is mounted directly onto the CD mechanism, this includes the CD loader motor and sled drivers, the servo driver and CD decoder.

The **main** PCB is mounted in the base of the chassis and contains the power supplies, optical and coaxial SPDIF output and the user interface microcontroller.

Disc reading/decoder module and servo PCB

The disc reading laser pickup is mounted in a motor driven slot loader, which receives its operating commands via the servo PCB.

The heart of the servo PCB is the CD decoder Integrated Circuit IC401. This is controlled by software running on the main board micro controller IC701 via an I²C Bus.

The microcontroller sends high level commands (e.g. Read TOC, Play track 1) to the servo PCB via a communication bus. Disc loading is controlled by the microcontroller on the servo PCB.

When a disc is inserted into the player the first thing that needs to happen is that the Table of Contents (TOC) of the disc is read. This information contains the start and end location of each track on the disc for disc navigation purposes.

In order to read the TOC the laser is switched on by the decoder IC, and a focus ramp is initiated. If focus is found then the disc motor is switched on for a short time, then the PLL is switched on and the disc is accelerated to full speed. Once the speed had been achieved and the PLL is locked onto the data, the radial loop is switched on and the subcode will be read from the disc and fed to the decoder.

The focus and radial positions of the laser spot are controlled by the decoder by looking at the diode signals coming from the optical pick up (OPU). These are D1,D2, D3 and D4 for focus, R1 and R2 for radial. The error signal from these diodes is used to generate a PDM signal. This signal is then filtered with a low pass filter and amplified by the motor driver (BA5984FP) to move the actuators.

Power for the laser diode is supplied directly from the decoder IC which monitors laser output and adjusts the power accordingly.

There is a single system clock on the servo board, 8.4672MHz. This is self-generated by the decoder IC.

There are 2 main power supplies to the servo board, +5V_CD for the signal processing electronics and +5V_MOTOR to IC402 supplying motor and sled power. The +5V_CD supply is sub regulated to +3V3 and sub-sub-regulated to +1.8V on-board for the decoder and other electronics.

TECHNICAL DESCRIPTION

Microprocessor control system

System control is provided by microcontroller IC701 on the main PCB. The microcontroller accepts external user commands (IR handset, front panel keys and MC-BUS loop) and translates them into instructions that operate the CD mechanism, via commands sent to the servo PCB.

The microcontroller communicates with the decoder on the servo PCB via the CD_CL and CD_DA lines.

Digital Outputs

The digital audio data from the servo PCB is fed to the main PCB via cable assembly CON701. The data is then buffered by IC601 and IC604. The SPDIF data is fed to the optical output (TOTX401) and to the RCA coaxial output (via digital transformer L402).

Power supplies

The internal regulated power supplies for the CD t are derived from a switching power supply on the main PCB. This has two separate outputs, +5V and +10V.

The 10V supply drives the display backlight via a switchable current source T702/T706/T707.

The 5V supply drives the other parts of the circuit.

Front panel display

The front panel display is a backlit LCD module mounted in a moulding behind the front panel. The LCD module is driven by signals from microcontroller IC701 pins 37 and 38 (DISP_DATA and DISP_SCLK). IC701 also reads back an analogue voltage encoded from keys pressed on the front panel (via KEYS_IN1 pin 7), and remote control information from the eye via line RC5_IN pin 32.

FAULT FINDING/DISASSEMBLY

CAUTION! LIVE MAINS VOLTAGES!

When undertaking any repair work on the CD player, engineers should note that the player includes a switching power supply connected directly to live mains and other high voltages, located on the main PCB. Capacitors in the power supply will retain very high DC voltages, even when disconnected from the mains. Exercise extreme care when removing or handling the main PCB.

Power supply repair

If a power supply fault is suspected, check the voltage of the 5V and 10V power supplies on the main PCB. These can be found at the SMD electrolytic capacitors C506 and C507. If either or both of these power supplies is missing, there may be a power supply fault or a short-circuit to the power supply in question.

The primary side of the power supply can only be tested with an isolated DVM when the main PCB is installed correctly in the chassis. Never connect power to the main PCB when it has been removed from the chassis or use any grounded test equipment such as oscilloscopes to check for primary faults.

Initially, check the DC supply voltage across the '+' and '-' pins of D501. The voltage found will depend on the mains voltage, but will be between 300-350V. If this voltage is not present, disconnect mains power and check the miniature fuse FS801. If the fuse is OK, remove the PCB and check the primary components with a DVM resistance meter.

If the DC supply voltage is present and the power supply is not running, check the voltage between pins 1 and 8 of IC501. This is about 0.9V in normal operation. If this voltage is low, check R501. Check also the bias supply between pins 2 and 8 of IC501. This should be around 6V, but will only be present if the switching supply is switching correctly. If the supply is not switching, suspect a problem with IC501 or TX501. TX501 can be checked with a DVM set for resistance.

The secondary supplies are simple rectified supplies. The 'FEEDBACK' line provides close regulation for the +5V supply while the +10V supply may vary a little in voltage. If the +5V supply is not accurately set, this is most likely a component fault in IC502 or the network of components around it.

Disc will not read

If the disc will not read, check to see if the disc is rotating. If the disc is rotating then it means that the laser has focussed on the disc, therefore all power supplies are ok. If the disc does not rotate then check the power supplies to the servo PCB at pins +5V_MOTOR and +5V_CD on connector CON405 of the servo PCB. If the power supplies are working correctly, remove the loader and substitute the laser pickup with a new replacement unit. If the disc will still not read, substitute with a new servo PCB.

CAUTION! When disconnecting the flexfoil cable from the laser pickup to the servo PCB, always ensure that static precautions are taken with a grounded static mat and wrist-strap as the laser pickup can easily be damaged by relatively low levels of static. When the disc reading mechanism or laser pickup are removed from the chassis, it is preferable to fit a flexfoil and use a metal paper clip or similar to bridge all open connections as static protection when handling the pickup.

FAULT FINDING/DISASSEMBLY

Removing the loading mechanism with laser pickup

- Disconnect mains power.
- Disconnect the flexfoil from CON405 on the servo PCB.
- Remove the two screws securing the mounting cradle to the chassis.
- Slide the loader and cradle back in the chassis to disengage the front, then lift the complete assembly from the chassis.

Removing the cradle

Once the PCB has been removed, the cradle can be separated from the loader after removing the two self-locking nuts.

Removing the servo PCB

In a static safe environment, disconnect the flex foil from CON401 on the servo PCB. Use a metal paper clip to short the exposed end of the flex-foil and protect from static damage. Disconnect the cable plugs from CON402, CON403 and CON404. The PCB securing screws can now be removed and the servo PCB lifted clear.

Replacing the loading mechanism with laser pickup

Replacement is generally a reversal of removal, but note the following important steps -

Once the servo PCB has been fitted and the flexfoil cable from the laser pickup connected to CON401, the solder-short that protects the pickup from static must be removed. This is accessible through the window on top of the loader as shown.

Removal of the solder-short static protection:

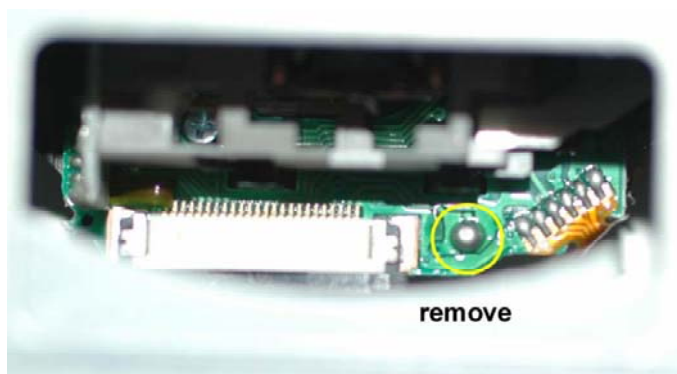

Once the solder-short is removed, the loader can be fitted to the cradle and then to the chassis.

Digital output faults

The digital output drive circuits are relatively straightforward. If the disc is playing, check the presence of the digital output signal from the DOBM pin of CON405 on the servo PCB. This signal should then appear on the main PCB at IC601, then IC604 before passing through L402 to the digital outputs.

Removing the front panel PCB

If a fault is diagnosed which requires the removal of the front panel PCB, proceed as follows. First, following the instructions above, remove the loading mechanism. Now disconnect the flexfoil running to the front panel PCB. Finally, the complete front panel assembly including display PCB may now be pressed forward out of the front of the chassis. Remove the fixing

FAULT FINDING/DISASSEMBLY

screws and the front panel PCB may now be lifted off the front panel assembly. The only part available for service of this PCB is the remote eye. If there are other faults with this PCB it will be necessary to replace the PCB assembly.

FLASH SOFTWARE

Flash Software Overview

The CD players feature upgradeable software for the control system. The main PCB includes a microcontroller with internal memory that includes the software.

The microcontroller is labelled during the manufacturing process to show which software version is installed. If the software version is revised at some point this indication should be clearly deleted with a cross marked on the device label. The most reliable method to check the software version (without dismantling the player) is to read it from the display as follows -

1. Connect power to the unit and set to Standby (power light red).
2. Press and hold the Standby key.
3. The software version will be shown on the display.

Re-programming

NOTE: Product software must never be replaced with an earlier version than already installed.

The CD players are programmed by connecting a USB cable directly from the main PCB to a computer. The location of the programming connector on the control PCB is arrowed in the picture on the right.

CAUTION: Ensure you have a new firmware file to hand before starting the process. Never disconnect the cable until the new software is installed.

1. Disconnect the mains from the product.
2. Locate SW702, a microswitch next to the USB connector shown in the drawing.
3. Press and hold SW702.
4. Connect a mini-USB cable to a free USB port on a computer.
5. Connect the mini-USB cable to the socket on the main PCB.
6. The Red LED on the main PCB will light to indicate that USB power is available.
7. Release SW702.
8. A new window will pop up on the PC which will show the current firmware.bin file.
9. Delete the existing firmware.bin file.
10. Copy the new firmware.bin file supplied by Cyrus to this folder.
11. Once the file has been copied remove the USB cable.
12. Power up and check the new software version as described above.

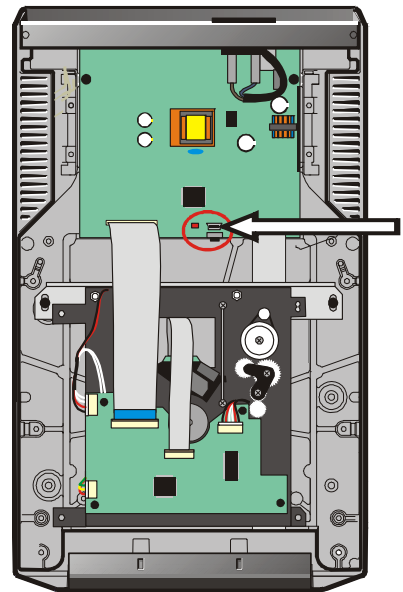

MC-BUS SYSTEM

The MC-BUS system

MC-BUS is a system which provides communication between the control systems of a number of Cyrus products. The communication takes the form of a serial data stream which is sent from a 'master' product and received and repeated by 'slave' products. The data is thus passed from one product to another around a loop. The master product should then receive the message back which confirms that loop connections have been correctly made. The CD player is a 'slave' product and listens for 'CD' commands from the master product in the loop (usually an amplifier or surround decoder).

MC-BUS internal signal routing

MC-BUS control is provided by the system microcontroller IC701. The signals are buffered into and out of this IC as shown in the diagram, The resistor bias at the MC-BUS input ensures that the line idles high (+5V) if no MC-BUS connection is made to another product.

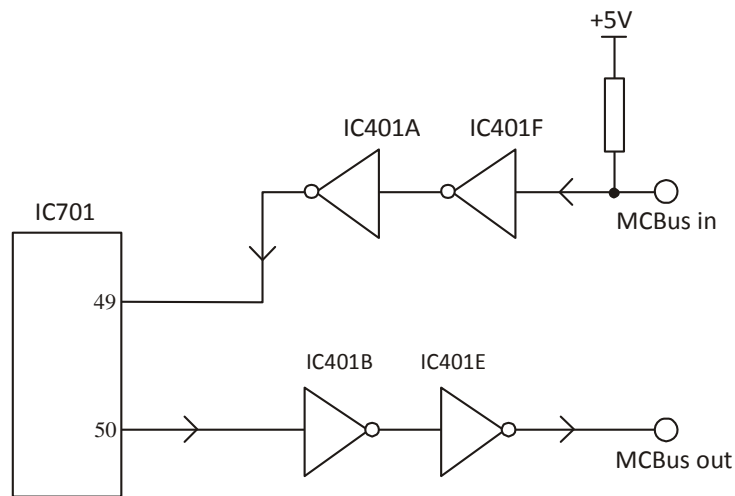

MC-BUS system tests

The MC-BUS system can be tested by connecting the CD player into a known working Cyrus system. Note that MC-BUS must be connected as a closed loop as shown in the diagram below. It is also important to connect the audio signal cables between components to provide an adequate ground return path for the MC-BUS signals. Switch on the power to the system and set all components to Standby. Selecting the CD input on the amplifier or switching on a surround decoder will now activate the CD player. When the amplifier is set to Standby, all other components connected to the MC-BUS loop will also set to Standby.

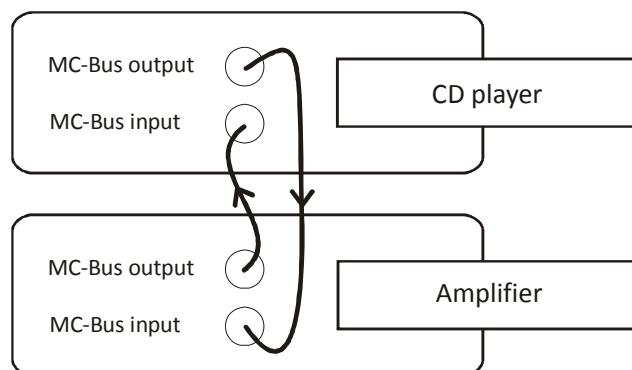

CHASSIS PARTS DRAWING

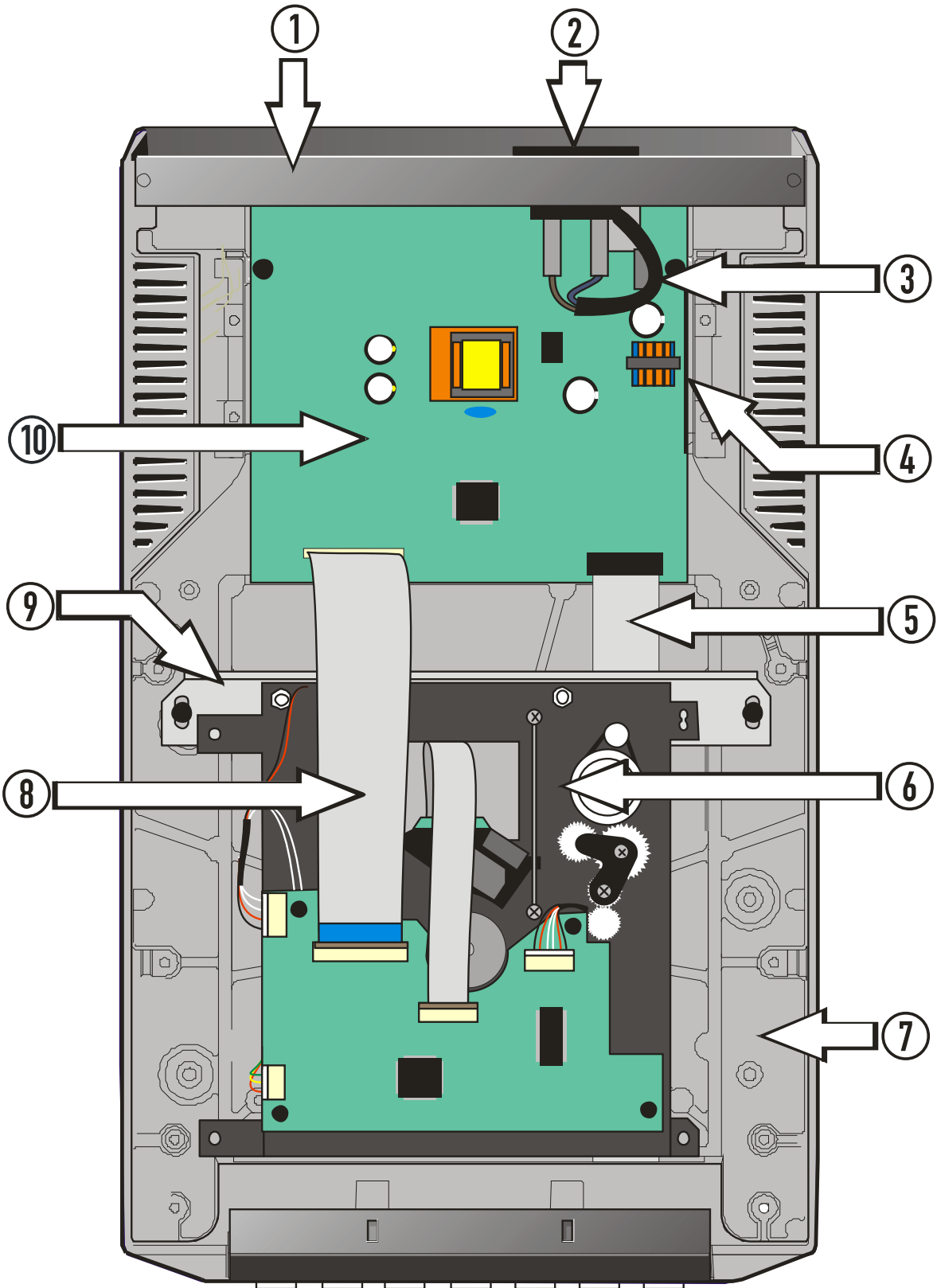

CHASSIS PARTS DRAWING

Main chassis

Ref	Part number	Description
1	I2-BACKP/T	Rear panel
2	AM-MTERM/	AC power inlet
3	I2-CBPOW/080	Power cable 80mm
4	I2-INSUL/	PCB insulator
5	I6-CB12W/200	Flex foil cable 12 way 200mm long
6	I2-LOADR/ASY	ASA CD mechanism including servo PCB
7	AM-COVER/BR AM-COVER/S1	Chassis - black Chassis - silver
8	I2-CB25W/170	Flex foil cable 25 way 170mm long
9	I2-CRADL/	Mechanism mounting cradle SE players
10	I2-MBSTD/T	Main PCB assembly

FRONT PANEL PARTS DRAWING

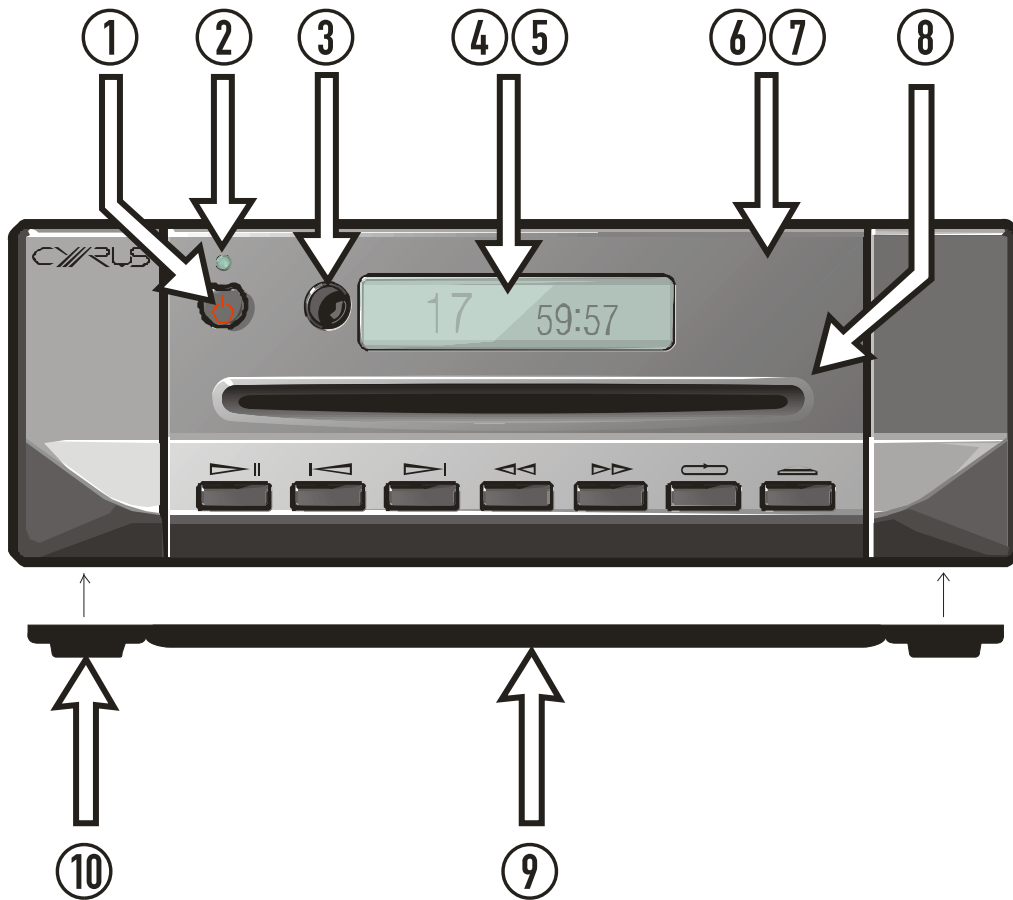

Front Panel parts

1	AM-POWCP/	Standby knob trim
2	AM-PLENS/02	Power lens
3	AM-LENSM/02	Remote eye lens
4	CD-DISPW/	Display window
5	I6-MBDIS/02	Display PCB
6	CD-FACSE/B CD-FACSE/S	Front facia black Front facia silver
7	I2-FRONT/ I2-FRONT/S	Technical Moulding black Technical Moulding silver
8	I2-BEZEL/	CD slot trim
9	AM-BPPLT/V0	Base plate
10	AM-BFOOT/	Rubber foot

MAIN PCB PART LIST

RESISTORS

R401	SMD0603	47k	TF 1/10W 1%	
R402	SMD0603	47k	TF 1/10W 1%	
R403	SMD0603	150R	TF 1/10W 1%	
R404	SMD0603		Not fitted	
R405	SMD0603	160R	TF 1/10W 1%	
R406	SMD0603	47R	TF 1/10W 1%	
R407	SMD0603	75R	TF 1/10W 1%	
R408	SMD0603	47k	TF 1/10W 1%	
R501	AXIAL0.5	3.9M	MF 0.6W 1%	
R502	SMD1206	22k	TF 1/4W 1%	
R503	SMD0603	1k	TF 1/10W 1%	
R504	SMD1206	39R	TF 1/4W 1%	
R505	AXIAL0.5	120R	MF 0.6W 1%	
R506	AXIAL0.5	120R	MF 0.6W 1%	
R507	SMD0603	560R	TF 1/8W 1%	
R508	SMD0603	10k	TF 1/10W 1%	
R509	SMD0603	10k	TF 1/10W 1%	
R511	SMD0603	130R	TF 1/10W 1%	
R512	SMD0603	18R	TF 1/10W 1%	
R602	SMD0603		Not fitted	
R603	SMD0603		Not fitted	
R604	SMD0603		Not fitted	
R605	SMD0603		Not fitted	
R606	SMD0603		Not fitted	
R607	SMD0603		Not fitted	
R608	SMD0603		Not fitted	
R609	SMD0603		Not fitted	
R610	SMD0603		Not fitted	
R611	SMD0603		Not fitted	
R612	SMD0603		Not fitted	
R613	SMD0603		Not fitted	
R615	SMD0603	100R	TF 1/10W 1%	
R619	SMD0603		Not fitted	
R620	SMD0603		Not fitted	
R621	SMD0603		Not fitted	
R622	SMD0603		Not fitted	
R623	SMD0603		Not fitted	
R624	SMD0603		Not fitted	
R701	SMD0603	1k	TF 1/10W 1%	
R702	SMD0603		Not fitted	
R703	SMD0603	1k	TF 1/10W 1%	
R704	SMD0603	120R	Ferrite bead	
R705	SMD0603	47k	TF 1/10W 1%	
R706	SMD0603	47k	TF 1/10W 1%	
R707	SMD0603	47k	TF 1/10W 1%	
R708	SMD0603	47k	TF 1/10W 1%	
R709	SMD0603	47k	TF 1/10W 1%	
R710	SMD0603		Not fitted	
R711	SMD0603	10R	TF 1/10W 1%	
R712	SMD0603	5R6	TF 1/10W 1%	
R713	SMD0603	1R0	TF 1/10W 1%	

MAIN PCB PART LIST

R714	SMD0603	1k5	TF 1/10W 1%	
R715	SMD0603	100k	TF 1/10W 1%	
R716	SMD0603	47R	TF 1/10W 1%	
R717	SMD0603	47R	TF 1/10W 1%	
R718	SMD0603	10k	TF 1/10W 1%	
R719	SMD0603		Not fitted	
R720	SMD0603	0R	TF 1/10W 1%	
R802	SMD0603		Not fitted	
R804	SMD0603		Not fitted	
R805	SMD0603		Not fitted	
R811	SMD0603	330R	TF 1/10W 1%	
R813	SMD0603		Not fitted	
R814	SMD0603		Not fitted	
RP401	SMD CAY16	100R	TF 1/16W 5%	
RP402	SMD CAY16	1k	TF 1/16W 5%	
RP601	SMD CAY16		Not fitted	
RP603	SMD CAY16		Not fitted	
RP605	SMD CAY16		Not fitted	
RP609	SMD CAY16		Not fitted	
RP701	SMD CAY16	100R	TF 1/16W 5%	
RP702	SMD CAY16		Not fitted	
RP704	SMD CAY16	10k	TF 1/16W 5%	
RP705	SMD CAY16	100R	TF 1/16W 5%	
RP706	SMD CAY16		Not fitted	

CAPACITORS

C401	SMD0603	47p	CP 50V 5%	
C402	SMD0603		Not fitted	
C403	SMD0603	22n	CP 25V 10%	
C404	SMD0603	22n	CP 25V 10%	
C405	SMD0603	22p	CP 50V 5%	
C406	SMD0603	22p	CP 50V 5%	
C407	SMD0603		Not fitted	
C409	SMD0603	1n	CP 50V 5%	
C413	SMD0603	1u	CP 16V 10%	
C414	SMD0603	100pF	CP 50V 5%	
C415	SMD0603	100n	CP 25V 10%	
C416	SMD0603	1n	CP 50V 5%	
C417	SMD0603	100n	CP 25V 10%	
C501	RB.2/.5	10uF	EL 450V 20%	
C502	RB.2/.5	22uF	EL 400V 20%	
C503	RAD0.3/RAD0.4	100pF Y1 CAP	Y1 250V 10%	May be 100pF or 2.2nF. Use 100pF for replacement.
C504	RB.2/.4	330uF	EL 25V 20%	
C505	RB.2/.4	1200uF	EL 16V 20%	
C506	CAPSMD6.3	100uF	EL 25V 20%	
C507	CAPSMD6.3	220uF	EL 16V 20%	
C508	RB.2/.2	1uF	EL 50V 20%	
C509	RB.2/.2	1uF	EL 50V 20%	
C510	RAD0.2/RAD0.3	100n	CP 630V 10%	
C511	SMD0603	100n	CP 25V 10%	
C512	SMD0603	100n	CP 25V 10%	
C513	SMD0603	560p	CP 50V 5%	

MAIN PCB PART LIST

C514	SMD0603	82p	CP 50V 5%
C516	RAD0.4	10n	PP 1kV 5%
C517	SMD0603	100n	CP 25V 10%
C601	SMD0603	22n	CP 25V 10%
C602	SMD0603		Not fitted
C603	SMD0603		Not fitted
C604	SMD0603		Not fitted
C605	SMD0603		Not fitted
C606	SMD0603		Not fitted
C607	SMD0603		Not fitted
C608	SMD0603	22n	CP 25V 10%
C609	SMD0603		Not fitted
C610	SMD0603		Not fitted
C611	CAPSMD5.0		Not fitted
C612	CAPSMD4.0		Not fitted
C613	RAD0.2		Not fitted
C614	SMD0603		Not fitted
C701	SMD0603	100n	CP 25V 10%
C702	SMD0603	100n	CP 25V 10%
C703	SMD0603	100p	CP 50V 5%
C704	SMD0603	22n	CP 25V 10%
C705	SMD0603	22n	CP 25V 10%
C706	SMD0603	22n	CP 25V 10%
C707	SMD0603	22n	CP 25V 10%
C708	SMD0603	22n	CP 25V 10%
C709	SMD0603	22n	CP 25V 10%
C710	SMD0603	22n	CP 25V 10%
C711	SMD0603	22n	CP 25V 10%
C712	SMD0603	1u	CP 16V 10%
C713	SMD0603	100n	CP 25V 10%
C714	SMD0603	100n	CP 25V 10%
C716	SMD0603	15p	CP 50V 5%
C717	SMD0603	15p	CP 50V 5%
C718	SMD0603	100n	CP 25V 10%
C802	RB.2/.5		Not fitted
C803	SMD0805		Not fitted
C804	SMD0805		Not fitted
C805	SMD0805		Not fitted
C806	SMD0603		Not fitted
C807	SMD0603		Not fitted
C808	SMD0603		Not fitted
C809	SMD0603		Not fitted
C810	SMD0603		Not fitted
C811	SMD0603		Not fitted
C812	SMD0603		Not fitted
C813	SMD0603		Not fitted
C814	SMD0603		Not fitted
C818	SMD0603	22n	CP 25V 10%
C819	SMD0603	22n	CP 25V 10%
C820	RAD0.8	100n X CAP	X2 250V 20%
C823	CAPSMD4.0		Not fitted
C824	RB.2/.5		Not fitted
C825	CAPSMD4.0		Not fitted
C826	CAPSMD4.0		Not fitted

MAIN PCB PART LIST

C828	SMD0603	22n	CP 25V 10%	
C829	SMD0603	22n	CP 25V 10%	
C830	CAPSMD4.0	22uF	EL 16V 20%	
CP701	SMD 0612-4	10n	CP 25V 10%	
CP702	SMD 0612-4	100pF	CP 100V 10%	
CP703	SMD 0612-4	100pF	CP 100V 10%	
CP704	SMD 0612-4	100pF	CP 100V 10%	

Key:

CP = ceramic plate. EL = electrolytic. PE = polyester. PP = polypropylene. BP = bi-polar.

CAPSMD6.3 refers to surface mount device with 6.3mm pitch pads

SMD-0805 refers to surface mount device size code 0805

DIODES

D401	SOT-23	BAS16	Signal diode	
D402	SOT-23	BAS16	Signal diode	
D501	DIODEBR2-SM	DF04S-E3	1A bridge rectifier	
D502	DIODE0.5	P6KE200A	Transient voltage suppressor	
D503	DIODE0.5	1N4935	Fast recovery diode	
D504	SOT-23	DA3X108K0L	Signal diode	Change to DA3X108K0L from BAS16
D505	SMC	SSC54-E3/57T	Rectifier	
D506	SMC	SS35-E3/57T	Rectifier	
D507	SOT-23	TL432ASA-7	Adjustable zener diode	
D701	SOT-23	KM-23HD	Red LED	
D803	SOT-23		Not fitted	
D804	DIODEBR2-SM		Not fitted	
D805	PSM		Not fitted	
D806	SOT-23		Not fitted	

TRANSISTORS

T701	SOT-23	DRC2113Z0L	Digital transistor	
T702	SOT-23	DRC2113Z0L	Digital transistor	
T703	SOT-23		Not fitted	
T704	SOT-23	DRA2114Y0L	Digital transistor	
T705	SOT-23	DRA2114Y0L	Digital transistor	
T706	SOT-23	BC807-25	Signal transistor	
T707	DPAK1	MJD32CT4G	SMD power transistor	
T801	SC-74-2		Not fitted	
T803	TO-220H2		Not fitted	
T804	SOT-23		Not fitted	
T805	SOT-23		Not fitted	
FET701	SOT-23	IRLML6401TRPbF		
FET702	SOT-23		Not fitted	

INTEGRATED CIRCUITS

IC401	TSSOP14	CD74HCT14PWR	Hex inverter	
IC402	VSOP24		Not fitted	
IC501	DIP-8C	TNY377PN	SWMPSU driver	
IC502	SO-4	SFH6206-2	Opto coupler	
IC601	SO-14	CD74HCT86M	Quad XOR	
IC602	TSSOP20		Not fitted	

MAIN PCB PART LIST

IC603	TSSOP14		Not fitted
IC604	TSSOP14	CD74HCT14PWR	Hex inverter
IC605	SO-16		Not fitted
IC606	TSSOP16		Not fitted
IC701	LQFP80	LPC1752FBD80	Microcontroller

VOLTAGE REGULATORS

VR801	SOT223		Not fitted
VR802	SOT223	LM1117MPX-3.3	800mA voltage regulator

FILTERS, INDUCTORS & CRYSTALS

L402	COIL_SMD_8x6	750050480	Pulse transformer
L501	COIL-ELF15	B82731M2132A030	6.8mH 1.3A
L502	SMDLH	4.7uH	SMD Inductor
L503	SMDLH	4.7uH	SMD Inductor
L601	SMD1210		Not fitted
L602	SMD1210		Not fitted
X701	XTAL_GSX-333	12.000MHz	Crystal
XTAL601	XTAL-SMD6		Not fitted

CONNECTORS & SOCKETS

CON601	CONLIF16T-SM		Not fitted
CON701	CONLIF25T-SM	528082570	25 way LIF connector
CON702	HEADER		Not fitted
CON703	SIL_6W		Not fitted
CON704	CONLIF12S	00-8370-127-000-800+	12 way LIF connector
CON801	2.8mm QC		Not fitted
CON802	2.8mm QC		Not fitted
CON803	3 PIN KK HEADER	0010321031	3 pin header
CON804	CONMINIPWR6		Not fitted
CON805	RAD0.1		Not fitted
SK401	PHONOSNGL	T6612AAAB	Single phono
SK402	PHONODUAL	12HP070HSG	Dual phono
SK701	CON-USB-67803	651005136421	Mini-USB connector

OTHER PARTS

FS801	FUSE_UMZ	3404.2416.11	Miniature fuse T1.0AL
RLY801	RELAY_G5NB		Not fitted
SW701	TACT-2-RTANGLE		Not fitted
SW702	TACT-2-RTANGLE	KSS321G LFS	Tact switch
TOTX401	TOX179	GP1FAV51TK0F	Optical transmitter
TX501	TX-EF20	094-931	SMPS TX

SERVO PCB PART LIST

RESISTORS

R401	SMD0603	220R	TF 1/16W 1%	
R402	SMD0603	750R	TF 1/16W 1%	
R403	SMD0603	10R	TF 1/16W 1%	
R404	SMD0603	10R	TF 1/16W 1%	
R405	SMD0603	100R	TF 1/16W 1%	
R406	SMD0603	100R	TF 1/16W 1%	
R407	SMD0603	10k	TF 1/16W 1%	
R408	SMD0603	47R	TF 1/16W 1%	
R409	SMD0603	100k	TF 1/16W 1%	
R410	SMD0603	24k	TF 1/16W 1%	
R411	SMD0603	22k	TF 1/16W 1%	
R412	SMD0603	3.6k	TF 1/16W 1%	
R413	SMD0603	30k	TF 1/16W 1%	
R414	SMD0603	3k6	TF 1/16W 1%	
R415	SMD0603	4.7k	TF 1/16W 1%	
R416	SMD0603	30k	TF 1/16W 1%	
R417	SMD0603	4.7k	TF 1/16W 1%	
R418	SMD0603	4.7k	TF 1/16W 1%	
R419	SMD0603	120R	BLM18SG121TN1D 0%	
R420	SMD0603	4.7k	TF 1/16W 1%	
R421	SMD0603	22k	TF 1/16W 1%	
R422	SMD0603	22k	TF 1/16W 1%	
R423	SMD0603	1R0	TF 1/16W 1%	
R424	SMD0603		Not fitted	
R425	SMD0603	10k	TF 1/16W 1%	
R426	SMD0603	100R	TF 1/16W 1%	
R427	SMD0603	2k2	TF 1/16W 1%	
R428	SMD0603	4.7k	TF 1/16W 1%	
R429	SMD0603	10k	TF 1/16W 1%	
R430	SMD0603	10k	TF 1/16W 1%	
R431	SMD0603	4.7k	TF 1/16W 1%	
R432	SMD0603	1R0	TF 1/16W 1%	
R433	SMD0603	30k	TF 1/16W 1%	
R434	SMD0603	4.7k	TF 1/16W 1%	
R435	SMD0603	3.6k	TF 1/16W 1%	
R436	SMD0603	22k	TF 1/16W 1%	
R437	SMD0603	1R0	TF 1/16W 1%	
R438	SMD0603		Not fitted	
R439	SMD0603		Not fitted	
R440	SMD0603	120R	BLM18SG121TN1D 0%	
R441	SMD0603	10k	TF 1/16W 1%	
R451	SMD0603		Not fitted	
R452	SMD0603	100R	TF 1/16W 1%	
R459	SMD0603		Not fitted	
R460	SMD0603		Not fitted	
R461	SMD0603		Not fitted	
R462	SMD0603		Not fitted	
R463	SMD0603		Not fitted	
R466	SMD0603	100k	TF 1/16W 1%	
R467	SMD0603	120R	BLM18SG121TN1D 0%	
R468	SMD0603	100k	TF 1/16W 1%	

SERVO PCB PART LIST

RP401	SMD CAY16	100R	TF 1/16W 5%	
RP402	SMD CAY16	100R	TF 1/16W 5%	
RP403	SMD CAY16	100R	TF 1/16W 5%	

CAPACITORS

C401	SMD0603	22n	CP 25V 10%	
C402	SMD0603	22n	CP 25V 10%	
C403	SMD0603	10n	CP 25V 10%	
C404	CAPSMD4.0	22uF	EL 16V 20%	
C405	SMD0603	22n	CP 25V 10%	
C406	SMD0603	100n	CP 25V 10%	
C407	SMD0603	100n	CP 25V 10%	
C408	SMD0603	100n	CP 25V 10%	
C409	SMD0603	1n5	CP 50V 5%	
C410	CAPSMD4.0	22uF	EL 16V 20%	
C411	SMD0603	22n	CP 25V 10%	
C412	SMD0603	22n	CP 25V 10%	
C413	CAPSMD4.0	22uF	EL 16V 20%	
C414	SMD0603	47n	CP 25V 10%	
C415	CAPSMD4.0	22uF	EL 16V 20%	
C416	SMD0603	100n	CP 25V 10%	
C417	SMD0603	100n	CP 25V 10%	
C418	SMD0603	22n	CP 25V 10%	
C419	SMD0603	100n	CP 25V 10%	
C420	SMD0603	22n	CP 25V 10%	
C421	SMD0603	22n	CP 25V 10%	
C422	CAPSMD4.0	22uF	EL 16V 20%	
C423	SMD0603	33pF	CP 50V 5%	
C425	SMD0603	100n	CP 25V 10%	
C426	SMD0603	100n	CP 25V 10%	
C427	CAPSMD6.3	100uF	EL 10V 20%	
C428	SMD0603	100n	CP 25V 10%	
C430	SMD0603	22n	CP 25V 10%	
C431	CAPSMD6.3	100uF	EL 10V 20%	
C432	SMD0603	1n5	CP 50V 5%	
C434	SMD0603	1n5	CP 50V 5%	
C435	SMD0603	1n5	CP 50V 5%	
C437	SMD0603	1n5	CP 50V 5%	
C438	SMD0603	1n5	CP 50V 5%	
C441	SMD0603		Not fitted	
C446	SMD0603	33pF	CP 50V 5%	
C447	SMD0603	100n	CP 25V 10%	
C448	SMD0603	100n	CP 25V 10%	

Key:

CP = ceramic plate. EL = electrolytic. PE = polyester. PP = polypropylene. BP = bi-polar.

CAPSMD6.3 refers to surface mount device with 6.3mm pitch pads

SMD-0805 refers to surface mount device size code 0805

DIODES

D401	LED_5MM	TSAL6200	Through Hole IR LED.	
D402	LED_5MM	TSAL6200	Through Hole IR LED.	
D403	SOD-123	1N4148W-V-GS08	small signal diode	
D404	SOD-123	1N4148W-V-GS08	small signal diode	
D405	SOD-123	1N4148W-V-GS08	small signal diode	

SERVO PCB PART LIST

D406	SOD-123	1N4148W-V-GS08	small signal diode	
------	---------	----------------	--------------------	--

TRANSISTORS

T401	SOT23	BC817-25	Signal Transistor	
T402	SOT23	PDTB113ZT	Digital transistor	
T403	SC-74-2	IMX17T110	Dual NPN transistor	

INTEGRATED CIRCUITS

IC401	LQFP80	SAA7826HL/M1AS/S5	PhonIC CD decoder	
IC402	HSOP28	BA5984FP-E2	5 channel motor driver	

VOLTAGE REGULATORS

VR401	SOT223	LM1117MPX-3.3	SMD +3v3 regulator.	
-------	--------	---------------	---------------------	--

FILTERS, INDUCTORS & CRYSTALS

X401	GSX-751	8.4672MHz	MP04546	
------	---------	-----------	---------	--

CONNECTORS & SOCKETS

CON401	CONZIF24-SM_0.5MM	046240024006800+	24 way LIF connector	
CON402	CON4-JST-SMS	S4B-PH-SM4-TB(LF)(SN)	4 way SIL header	
CON403	CON3-JST-SMS	S3B-PH-SM4-TB(LF)(SN)	3-way SIL header	
CON404	CON6-JST-SMS	S6B-PH-SM4-TB(LF)(SN)	6-way SIL header	
CON405	CONZIF25	52271-2579	25 way ZIF connector	
SK401	SKT_SMB		Not fitted	
TP414	PAD6.0x6.2	S1951-46R	Spring terminal	
TP415	PAD6.0x6.2	S1951-46R	Spring terminal	

CIRCUIT DIAGRAMS

Circuit diagram index

The Cyrus CD t circuit diagrams are listed below.

Main PCB

Digital output and MC-BUS	25
Power supply	26
Microcontroller	27

Servo PCB

Decoder and sled drive.....	28
-----------------------------	----

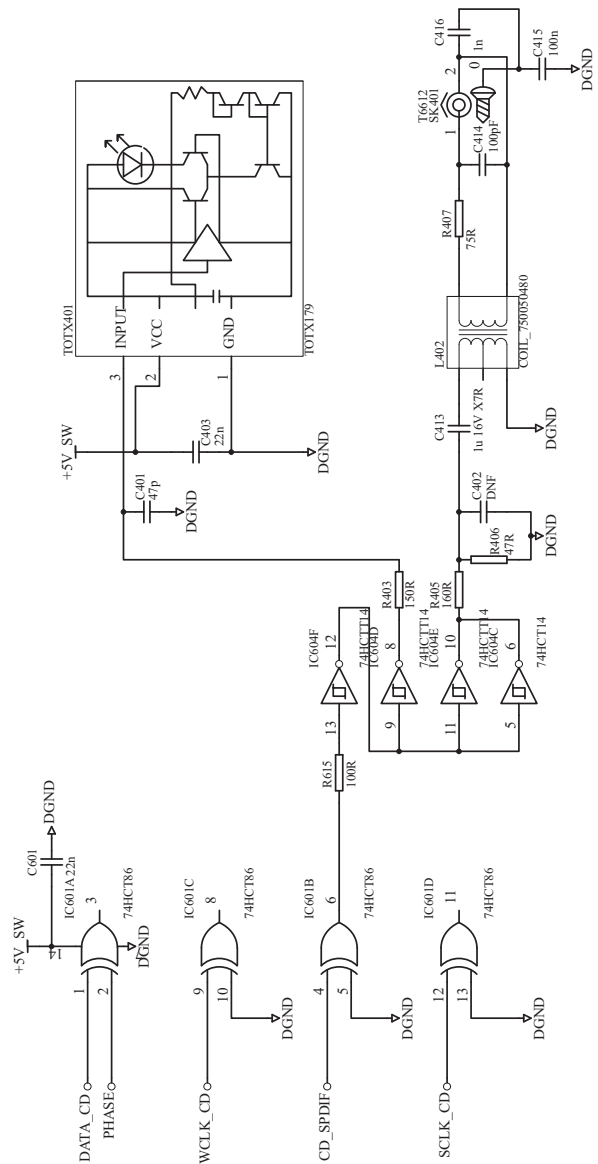
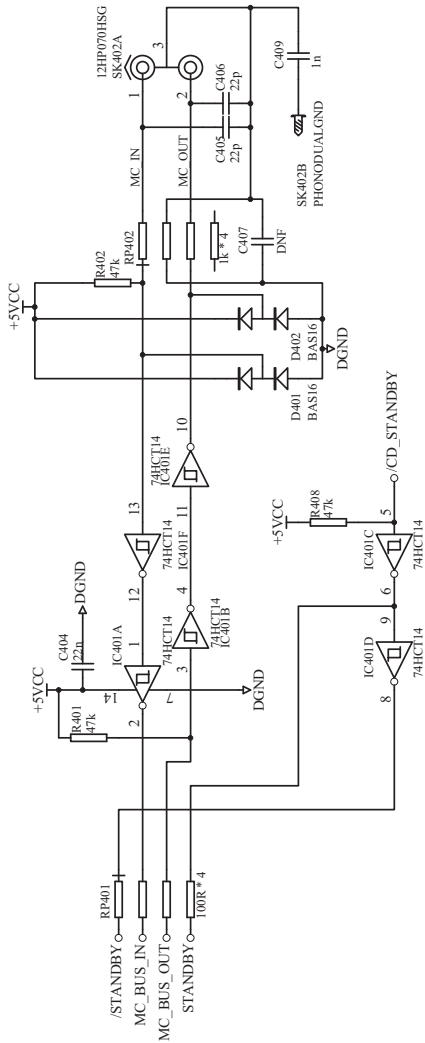

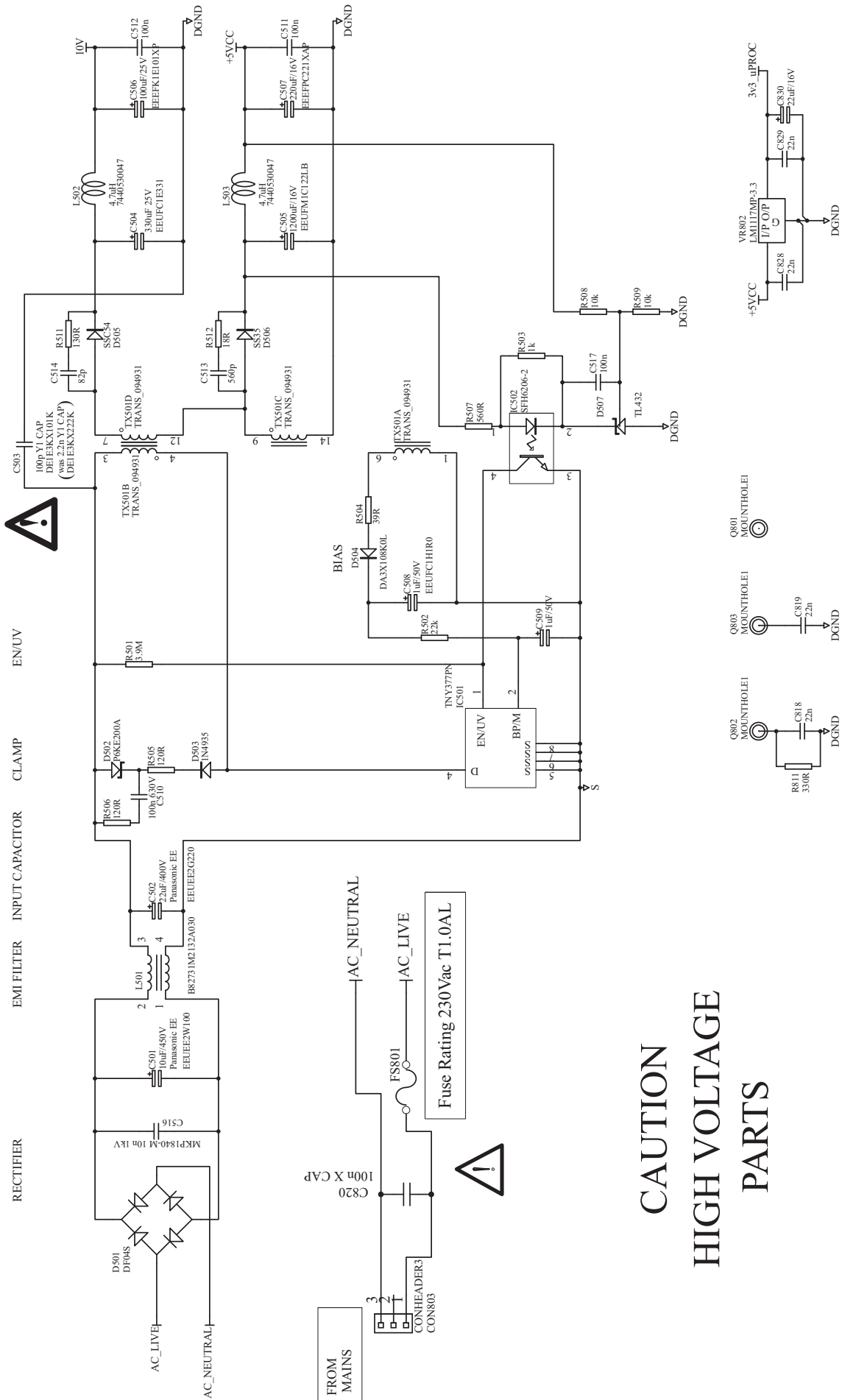

**CAUTION
HIGH VOLTAGE
PARTS**

SAFETY CRITICAL COMPONENT
REPLACE WITH APPROVED PART



